

[Studies in Language Companion Series, 173] 2016. viii, 416 pp.

Language Contact and Change in the Americas

Studies in honor of Marianne Mithun

Editors

Andrea L. Berez-Kroeker | University of Hawai'i at Manoa

Diane M. Hintz | SIL International

Carmen Jany | California State University, San Bernardino

This unique collection of articles in honor of Marianne Mithun represents the very latest in research on language contact and language change in the Indigenous languages of the Americas. The book aims to provide new theoretical and empirical insights into how and why languages change, especially with regard to contact phenomena in languages of North America, Meso-America and South America. The individual chapters cover a broad range of topics, including sound change, morphosyntactic change, lexical semantics, grammaticalization, language endangerment, and discourse-pragmatic change. With chapters from distinguished scholars and talented newcomers alike, this book will be welcomed by anyone with an interest in internally- and externally-motivated language change.

Publishing status: Available

© John Benjamins <https://doi.org/10.1075/slcs.173>

Table of Contents

Foreword	vii–viii
Language contact and change in the Americas: The state of the art <i>Sarah G. Thomason</i>	1–14
Part I North America: California	
Yuki, Pomoan, Wintun, and Athabaskan: Language Contact in Round Valley, California <i>Uldis Balodis</i>	15–32
The role of passives in the formation of hierarchical systems in Northern California <i>Carmen Jany</i>	33–66
Assessing the effects of language contact on Northeastern Pomo <i>Neil Alexander Walker</i>	67–90
Synchronic and diachronic accounts of phonological features in Central Chumash languages <i>Timothy P. Henry</i>	91–104
Part II North America: Athabaskan, Iroquoian, and Uto-Aztecan	
Contact and semantic shift in extreme language endangerment: Ahtna riverine directionals in a cardinal world <i>Andrea L. Berez-Kroeker</i>	105–138
“Excorporation” in a Dene (Athabaskan) language <i>Keren Rice</i>	139–166
Contact and change in Oneida <i>Clifford Abbott</i>	167–188
Huron/Wendat interactions with the Seneca language <i>Megan Lukaniec and Wallace Chafe</i>	189–218
The usual suspects: Multiple grammaticalization of ‘do’, ‘be’, ‘have’, and ‘go’ in Ute <i>T. Givón</i>	219–246
Part III Northern Mexico, Mesoamerica, and South America	
Language documentation and historical linguistics <i>Lyle Campbell</i>	247–272
The Jakalteq Popti’ noun classifier system: Changes due to Spanish contact <i>Colette Grinevald</i>	273–296
Language contact and word structure: A case study from north-west Amazonia <i>Alexandra Y. Aikhenvald</i>	297–314
Auxiliation and typological shift: The interaction of language contact and internally motivated change in Quechua <i>Daniel J. Hintz</i>	315–338
Discourse pattern replication in South Conchucos Quechua and Andean Spanish <i>Diane M. Hintz</i>	339–362
Part IV The Americas and beyond	
Measuring language typicality, with special reference to the Americas <i>Bernard Comrie</i>	363–384
Words for ‘dog’ as a diagnostic of language contact in the Americas <i>Matthias Pache, Søren Wichmann and Mikhail Zhivlov</i>	385–410
Index	411–416

“This book starts in California, as is fitting for a book in honor of Marianne Mithun, and then works its way outward, reflecting the state of knowledge about language contact and change in the Americas, where considerably more is known about North America but where South America offers exciting new areas for research in this field. The book is a just tribute to one of the most important contemporary scholars of American indigenous languages, and to someone for whom language contact and change have been central motifs.”

Nora C. England, *The University of Texas at Austin*

“Marianne Mithun's work has influenced a generation of scholars, helping to shape the direction of scholarship in Native American languages. Inspired by Mithun's passion and flair for seeking explanation within the wider context of language use, the authors explore a range of contact phenomena relevant not only to the Americas but to our understanding of language evolution more broadly. The breadth and depth of these contributions provide clear evidence of a bright future for Americanist linguistics.”

Gary Holton, *University of Hawai'i at Mānoa*

The Jakaltek Popti' noun classifier system

Changes due to Spanish contact

Colette Grinevald*

DDL, Université Lyon

After having resisted adaptation in the 70s, the Jakaltek Popti' (of the Q'anjob'alan family) noun classifier system has recently undergone extensive restructuring. These changes are largely due to the need that was felt to classify nouns of Spanish origin for artifacts made of untraditional or new materials that have been incorporated into the language and culture. The absence of classifiers for these nouns meant an absence of anaphoric pronouns, in contrast to the obligatory article and pronominal forms organizing the vocabulary of the dominant colonial Spanish language through gender-marking. Discussions with the local branch of the Academy of Mayan Languages of Guatemala, the Jakaltek linguistic community, reveal their concern with revitalizing and standardizing the now clearly endangered Jakaltek Popti'.

Keywords: noun classifiers; Jakaltek Mayan; contact; revitalization

Introduction

Jakaltek Popti' is a Mayan language of the Q'anjob'alan branch of the family spoken in the northwest corner of the Cuchumatanes mountains of Guatemala, on the border of Mexico and looking down on Chiapas and its Tzeltalan Mayan languages. The language was spelled Jacalteco until it became Jakaltek, following the standardization of the Mayan alphabets promoted by the Academy of Mayan Languages of Guatemala. It was then changed to Jacalteco Popti' by the local Jakaltek branch of the Academy.¹

* The author was known as Colette Craig from the University of Oregon until 1996, when she returned to France and changed back to her maiden name of Grinevald.

1. Hence Craig writing about Jacalteco and Grinevald about Jakaltek Popti', using both names to allow readers to make the connection with earlier writings and the new Academy publishing work on Popti'.

The language is probably best known in the literature for its noun classifier system, an interesting characteristic of the Q'anjob'alan branch of the family. The identification of such a noun classifier system distinct from other subtypes of classifier systems has played a major role in the establishment of a typology of classifier systems. (see Craig 1986, 1987; Grinevald 2000, 2015; Goldwasser & Grinevald 2012, *inter alia*). Within the Mayan family itself this system is to be distinguished from the numeral classifiers of the Tzeltalan branch of Chiapas (see Berlin 1968 for Tzeltal and de Leon 1988 for Tzotzil).

After a general introduction of this classifier system (Section 1), based on how it functioned in the 1970s at the time of the majority of the fieldwork on the language, the present paper treats the question of how language contact with the dominant colonial Spanish language has impacted the system in different ways at different times. Resistance versus openness is contrasted first, in Section 2. The rigidity of the system in the 1970s, characterized by a definite resistance to accommodate objects of modern life in the classification schema, in spite of easy lexical borrowing from Spanish, is established first as a point of comparison. This is then briefly contrasted with the apparent openness of the system centuries before, at the time of colonization. The major and newest part of the paper, Section 3, is an account of the pervasive variation encountered and the extensive changes observed to be taking place in the system's functioning at the turn of the 21st century, thirty years after the initial major fieldwork, due to contact with Spanish. A final discussion in Section 4 will then recast these three types of response to contact with Spanish, from openness to resistance to a major restructuring of the system, within the different sociolinguistic contexts in which they happened. It will emphasize in particular how the new extensive changes must be viewed within a context of language endangerment and official efforts at language revitalization, in which the currently very endangered Jakalteq language is the object of standardization, looking to the dominant language, Spanish, as a model.

1. Outline of the Jakalteq noun classifier system

It is interesting to note that, while ample data on the noun classifier system was gathered in the 70s, the most productive period of its analysis as a classifier system did not come until a decade later. This is a clear case of collected data that laid unused for a period of time, waiting for new questions to be asked of them, in the vein of Mithun's constant encouragement to document un(der)described languages as they present themselves, without limiting data collection to respond to contemporary debates, but making sure to collect ample natural data that will then be ready to answer possible future questions (Mithun 1990, 2001).

1.1 The categorization schema of the Jakaltek noun classifier system

The motivation for the first studies of the Jakaltek classifiers as an actual nominal classifier system came more than a decade after data collection, as new questions were raised by ongoing discussions of universal semantic properties of classifier systems on the one hand, and the development of a new field of cognitive linguistics, on the other.²

As presented in Craig (1986), the Jakaltek Popti' system has an inventory of 24 classifiers, which are divided into two sets, each one with its own dynamics. A dozen classifiers categorize the human and supernatural world (between kinship relations and honorifics) and exhibit a certain degree of discourse flexibility (like the possibility of choosing a classifier in order to insult or exalt a person), as described in Craig (1977) and as discussed by anthropologists Day (1973) and Breitborde (1973). The focus of this paper is the part of the system that categorizes the non-human world, consisting of the other dozen classifiers.

Items of this inventory for the non-human world function at different levels of categorization, some heading large classes and identified as generic (ANIMAL/PLANT/ROCK/SOIL/WATER), others heading more restricted classes and identified as specific (CORN/CORD/THREAD/CLOTH), and finally, some heading a class of one item, called unique classifiers (DOG/SALT/FIRE). As shown by Hopkins (2012), the classifier inventories of the Q'anjob'alan languages vary, the Jakaltek inventory being one of the most extensive and the only one to have classes of THREAD/CLOTH/DOG, for instance. Craig (1986) considered the cultural relevance of the non-generic classifiers, such as the specific classifiers CORN (pan-Mayan trait) and THREAD (for the local craft of cotton weaving), which might have been expected to be items included in the generic PLANT class. The same could be said of the unique classifiers, such as SALT (known as being important for monetary exchange in the whole region), and DOG (to be considered in the very local context of Jacaltenango, where owning a dog is considered to be a mark of adult male identity).

A developed process of class extension was also accounted for, from source entities to isolated parts of those entities, to manufactured products made with the same material. The largest classes identified were those of ANIMAL and PLANT, with all their parts and derived products. The ANIMAL class, for instance, includes animals (pig/cow/chicken/snake/bird, etc.), animal parts (meat/milk/egg) and manufactured objects made of animal materials (leather sandals/woolen blankets). The PLANT class includes plants (all kinds of trees/plants and their parts: fruits/flowers/leaves, etc.) and objects manufactured from them, such as planks and pieces of furniture, as well as foods. There were also interesting cases of extensions of classes to accommodate new

2. The existence of a system had been noted in La Farge and Byers (1931) and part of its semantics had been studied by Day (1973).

materials non-native to the culture (as with the original ROCK class absorbing metal and glass objects and the CORN–maize class absorbing wheat and wheat products), as well as opposite cases of resistance to classification. Both of these are special situations, considered below in Section 2.

From the start it was the semantic transparency of the classifiers that made it relatively easy to interpret the mode of categorization of the Jakaltek system. As a matter of fact, all but one of the classifiers were of clear nominal origin (the exception being the one for dog, *metx'*, which in addition happens to be a unique classifier, classifying only dogs). The majority actually originate in repeaters, as full or truncated forms of identifiable nouns, which then undergo expected semantic bleaching when functioning as classifiers, as for instance *te'* 'tree, trunk'/CL *te'* for all plants and plant products, including wood; *ha'* 'water'/CL *ha'* for water bodies (rain, lake, river, etc.) and *ch'en* 'rock'/CL *ch'en* for rock objects originally, extended to metal or glass objects as discussed in Section 2.2. It was therefore clear that the categorization operated based on the material of the entities classified, as shown by the various classifications of drinkable liquids according to their source liquid: CL/WATER for water and CL/ANIMAL for milk, but CL/PLANT for tea, coffee, and alcohol. The fact that the classification did not operate based on the shape of objects – which is the usual situation for numeral classifiers in which 'tree/fruit/leaf' are common lexical sources of shape classifiers for 1D/2D/3D items – was a key factor used in establishing a new subtype of classifiers, called noun classifiers.

1.2 A grammaticalized noun classifier system

Early on, Craig (1977, 1979, 1987) established the central importance of the Jakaltek classifier system in the grammar of the language, discussing the classifiers back then under the labels of "determiners" and "pronouns". These two main grammatical functions of classifiers account for their omnipresence in the language. The fact that these functions correspond to similar ones in Indo-European languages will be taken up again in the final discussion of why so many changes in the system have occurred in recent times – times of increased impact of Spanish on the system and in the midst of revitalization efforts for the now endangered language.

Example (1a) shows classifiers as determiners (CL + NOUN) and then (1b) shows them in an anaphoric function (CL alone):³

3. Examples are given here in the current writing system used by the academy, in which the apostrophe (') marks glottal phenomena (whether glottal stops or glottalized consonants), *x* and *tx* are for retroflex fricative and affricate respectively, standing in opposition to *xh* and *ch*, the corresponding non-retroflexed fricative and affricate. Crucially here, *k* is used for the velar stop (replacing the Spanish-based *c/qu*) in contrast to *q* itself, used here for the postvelar stop. Hence *jacaltec* and *k'anjobalan* are now spelled *jakaltek* and *q'anjobalan*. The only gloss, CL, stands for classifier.

- (1) a. *swatxè ix malin ixim wah ?*
 made CL/WOMAN Marie CL/CORN tortilla
 ‘Did Mary make the tortillas?’
- b. *ho’ swatxè ix ixim*
 yes, made CL/WOMAN CL/CORN
 ‘yes, she made them’

The main interest for syntacticians in the 70s turned out to be the participation of these classifiers in marking (co-)referentiality chains, by indicating coreferentiality through the deletion of the corresponding classifier, a phenomenon labeled then coreferential “gapping” (amply discussed in Chapter 5 of Craig 1977 and of clear interest to theoreticians of the time and place – Harvard and MIT in the 1970s).

Examples (2a) and (2b) illustrate situations of non-coreferentiality (Peter vs. Mathias) with the corresponding doubling of the classifier *naj*; (2c) shows where the absence of the second classifier must be interpreted as the result of the deletion of a coreferential classifier:

- (2) a. *xil naj pel s-mam naj maltixh*
 saw CL/MAN Peter his-father CL/MAN Mathias
 ‘Peter saw Mathias’s father’
- b. *xil naj pel s-mam naj*
 saw CL/MAN Peter his-father CL/MAN
 ‘Peter saw his (someone else’s) father’
- c. *xil naj pel s-mam*
 saw CL/MAN Peter his-father
 ‘Peter saw his (own) father’

This advanced status of grammaticalization, or better said, syntacticization of the Jakaltek noun classifier system is discussed in Grinevald (2002), and presented as one of the elements of a multidimensional typology of classifier systems, one that takes into account the specific dynamics of each particular classifier system. So the Jakaltek system in the 1970s was both highly semantically motivated and highly syntacticized.

1.3 How the specifics of the Jakaltek system fed a typology of classifier systems

The elaboration of a typology of nominal classification systems first presented in Craig (1987, 1992) and elaborated in Grinevald (2000, 2015) was clearly initially motivated by the recognition of a particular subtype of nominal classifier systems, named then ‘noun classifiers’, mainly on the basis of this Jakaltek system.

Several characteristics help to distinguish the four major subtypes of classifier systems. The first characteristic is morphosyntactic in nature and is linked to positions

of classifiers in relation to the host, and to host categories as well, yielding a contrast between genitival, numeral, noun, and verbal classifiers, as shown in Figure 1.

[POSS+CL <i>genitival</i> <i>classifier</i>	Numeral+CL <i>numeral</i> <i>classifier</i>	CL+Noun] <i>noun</i> <i>classifier</i>	//	Verb-CL <i>verbal</i> <i>classifier</i>
---	---	--	----	---

Figure 1. Major subsystems of nominal “classifiers” (after Craig 1987 and Grinevald 2000)

Secondly, some languages can have two such systems. For instance, Ponapean has both numeral and genitival systems (Rehg 1981), and Akatek Maya has both noun and numeral systems (Zavala 2000).

The third characteristic is semantic and functional in nature, and consists of a correlation between three of the major morphosyntactic types of classifiers presented in Figure 1 (genitival, numeral, and noun) and distinct semantic categories. It links numeral classifiers with physical properties (as in 1D/2D/3D), noun classifiers with basic nature and material properties (as in animal, wood, rock/metal, water, etc.), and genitival classifiers with functional properties (food, clothing, transport), as given in Table 1.⁴

Table 1. Different semantic profiles for different types of classifiers

numeral classifiers = physical categories

one-LONG RIGID canoe

two-LONG RIGID pencils; three-ROUND oranges;

four-FLAT FLEXIBLE blankets

genitival classifiers = functional categories

my-TRANSPORT canoe

your-TRANSPORT bicycle; **his** EDIBLE fish;

his-DRINKABLE potion

noun classifiers = material/essence categories

a **PLANT** canoe

a **PLANT** house, a **ROCK** cave; an **ANIMAL** deer

The new data on Jakalteq Popti’ therefore offered a convincing case of classification based principally on the material or essence of the item classified, through a process of de-semanticization of generic nouns of objects used as lexical sources into classifiers of material. However, this classification had limitations, which will be described in the next section.

4. Verbal classifiers are not included because their categorization domain depends on the characteristics of their lexical sources (nouns or verbs) and they follow any one of the patterns outlined in Table 1.

2. A frozen system in the 1970s, that had been more open at colonization time

While the noun classification system of Jakaltek was highly motivated, it was, at the same time, clearly excluding an increasing number of items of daily use. It only applied to the classification of known objects produced locally (with some exceptions to be considered later). In the 1970s this constraint on classification actually produced the impression of a frozen system unable to cope with modern items recently introduced into daily culture. This situation, to be described next, of a 'frozen' system will later be contrasted with the apparently more open and adaptable system of centuries before, at the time of the initial encounter between Jakaltek and colonial Spanish.

2.1 Constraints on the classification schema in the 1970s

It seemed then that the conditions for classification were that the objects classified be accessible to various senses, for instance that they be touchable and controllable. This accounted for the exclusion from classification of natural phenomena such as the sun and the moon (actually classified as deities in the other subsystem of classifiers), or wind (classified as man). Ashes and swept garbage were not classified either. An important constraint on classification was that the object be part of the traditional way of life, made with familiar material, and using a known mode of fabrication.

New products of unknown material resisted classification, such as foreign drinks (beer and Coca Cola) and plastic objects (shoes, plates, cups, buckets, rain covers, etc.), although they had all become readily available in the market. The rationale for leaving these items unclassified was clearly articulated by speakers. For instance, traditional speakers could give a reason why beer could not be classified: they would say that it was because they did not know its material of origin nor the process by which it was produced. Even when the author presented pictures of fields of hops and breweries and suggested that beer could be classified as *PLANT*, their standard answer was simply *saber* 'who knows!'

By the mid-seventies the local market was in fact more and more invaded by a growing number of types of goods brought in from the big town of Huehuetenango, once trucks could reach the town of Jacaltenango through a new road. The effect on the language was that a growing number of nouns designating those new objects added to the list of unclassified items. On the other hand, this definite resistance to incorporation into the classifier system for items made, by and large, of plastic material clearly contrasted with the way all the new products made of metal or glass (like airplanes, cars, buses, TVs, eye glasses, flashlights, etc.) could, for their part, easily be incorporated into the classifier system, into the *ROCK* category, as will be discussed below in Section 2.2.

It is worth noting here the impact of the non-classification of many by-then-familiar objects on the functioning of the grammar, since it automatically led to the corresponding absence of anaphoric forms used for reference tracking in discourse. Although this situation seemed to be tolerated at that time, this drastic increase in the number of unclassified items was finally perceived by 2000 as a problem to be solved (as discussed in Section 4.2), particularly in the face of the regularity of pronoun use in the dominant Spanish language.

When objects made of unknown or non-traditional materials remained unclassified, their actual material could be specified in the N2 of an N1-N2 noun compound (see Table 2), although only when it was felt pragmatically necessary to do so. Items could therefore be mentioned in one of two constructions, either in a prenominal classifier construction for traditional materials, or in a noun compounding with a postnominal mention of the non-traditional material, as illustrated in the contrasting constructions in (3) below:⁵

- | | | | | | | |
|-----|----|------------|----------------------|-----|-----|----------------------------|
| (3) | a. | <i>No'</i> | <i>cheh</i> | vs. | a'. | <i>cheh te'</i> |
| | | CL/ANIMAL | horse | | | horse plant |
| | | | 'a/the horse' | | | 'a/the wooden (toy) horse' |
| | b. | <i>No'</i> | <i>sapato*</i> | vs. | b'. | <i>sapato* plastiko*</i> |
| | | CL/ANIMAL | shoe | | | shoe plastic |
| | | | 'a/the leather shoe' | | | 'a/the plastic shoe' |

It is worth noting here that the non-classification of the plastic shoe was not due to the fact that it was named through borrowed nouns, as both *sapato* and *plastiko* are clear borrowings (hence marked *) from Spanish *zapato* and *plástico*, respectively.

2.2 Earlier adaptability of the system in colonial times

Some information about the classifier system in colonial times, about 500 years earlier, can be extrapolated from the data collected in the 20th century by studying the treatment of Spanish loanwords for new cultural items brought in by the Spaniards. In the face of the drastic cultural changes that accompanied the process of Spanish colonization, the evidence suggests that these much-needed loanwords were absorbed into the classifier system. This inclusion points to the state of relative openness and adaptability of the system at that time, in contrast to the frozen state of the system, described above, that was encountered in the 1970s.

It is specifically this process of adaptation of Spanish loanwords to the constraints of Jakalteq phonology that helps date those loanwords to previous centuries, since

5. All borrowings from Spanish are marked with * for easy identification, in anticipation of the discussion of how the classifier system has handled loanwords through time.

more recent loanwords have not undergone such adaptation, resulting in a further extension of the phonological inventory of the language. As shown in the examples below, characteristics of this early adaptation of Spanish loanwords include the simplification of consonant clusters, either through simplification to a single consonant or through the creation of an additional open syllable and the replacement of *r* with *l*, as illustrated in (4):

- (4) Early borrowing from Spanish
- | | | | | |
|----|----------------|---|-----------------|---------|
| a. | <i>clavo</i> | > | <i>lawuxh</i> * | ‘nail’ |
| b. | <i>plato</i> | > | <i>pulato</i> * | ‘plate’ |
| c. | <i>carnero</i> | > | <i>kanelu</i> * | ‘sheep’ |

Spanish borrowings could then be assigned to classes, like ‘sheep’ to CL/ANIMAL. Most interesting is that new items made of new materials such as metal or glass were absorbed into the classification system through the extension of the class headed by the classifier *chèn*, repeater classifier of the lexical source *chèn* ‘rock’, until then reserved for rocks and objects strictly made of rock (like the traditional rock instruments to grind corn, for instance). This classifier had actually already undergone a process of de-semanticization from rock material to materials with a rock-like hard and cold consistency (as in the contrast CL/WATER rain but CL/ROCK hail). This allowed for the extension of the class to metal and glass objects (as in CL/ROCK guns, nails, glass, pitcher). It is this early class extension that permitted, as documented in the 1970s, the incorporation of modern items made of metal and glass into the system, already mentioned above, such as modes of transportation (car, bus, airplane, etc.) and items of modern technology (camera, tape recorder, television, computer, etc.). In a parallel way, the class of corn and corn-made foods, the principle staple of the Mayan culture, was extended in colonial times to incorporate the newly introduced wheat items, creating a larger class of cereal and cereal-based foods.

3. Extensive changes in the system by 2000

After a gap of more than twenty years, new fieldwork took place in the summers of 2001 and 2002 that revealed extensive changes in the functioning of this classifier system. It is interesting to note that this fieldwork had originally been planned for a cognitive linguistics experimental project meant to study the potential impact of classifier systems on categorization tasks, along the lines of the experimental work by Lucy (1996), much discussed back then, comparing results of categorization tasks by English speakers with those of Yukatek Maya speakers with a numeral classifier system.

Although much data came out of this new fieldwork in Jacaltenango, nothing was ever written or published about the cognitive linguistic aspect of the experiment, in

great part because the situation at hand seemed to be in a state of too much flux to arrive at any conclusion in that domain. The most unexpected and striking result of this fieldwork turned out to be finding evidence of a major change in the functioning of the Jakaltek noun classifier system. And as it were, this change in itself voided much of the validity of the experiments which had been designed for the system as it functioned in the 1970s, when the language was still vital (or widely spoken). This section will account for the impressive state of variation and innovation in the system discovered then, through which essential aspects were being restructured.

3.1 Data collection

The first summer of new fieldwork was dedicated to applying the type of experimental kit used by Lucy (1996), consisting of triads of objects matched by shape or by material, and asking speakers to indicate which two objects “went together”. After it became evident that the language had developed new rules for assigning classifiers, with much variation for certain items and across speakers, the following summer was dedicated to eliciting new data focusing on the use of noun classifiers with different types of objects. In both summers, the stimuli used were real objects, some collected in homes, some bought in the local market, and others brought in from out of town where they had been purchased in tourist shops.

With the specific goal of studying the new uses of these classifiers, the objects were chosen on the basis of two criteria: their materials and the degree of expected familiarity the speakers would have with them. In terms of materials, the set contained objects made traditionally and locally, either with raw basic materials (such as wooden spoons, clay pots, etc.) or manufactured from derived materials (such as cloth, leather, woolen objects, etc.). In terms of familiarity of the objects, a criterion clearly important in the categorization scheme, three sets of objects were organized according to the following categories: (i) traditionally locally produced (leather sandal, straw hat, glass necklace, clay plates); (ii) relatively new and of non-traditional material but now readily available and widely used (plastic shoes, sneakers, plastic and metal plates, plastic and metal flashlights); and (iii) relatively to completely foreign, from tourist markets, of identifiable use but relatively unfamiliar (woolen hat, cloth cap, seed bead necklace, leather or woolen purse).

The 34 speakers tested had different levels of language dominance (in either Spanish or Jakaltek Popti’) and different levels of education (from fluent bilingual school teachers and members of the language academy to Jakaltek-dominant housewives and peasants), as well as different provenance (from town or from more or less isolated and traditional hamlets). They were also of different age groups (from three generations, with traditional speakers in their seventies and semi-speakers in their twenties). It is worth noting that all the data collection activities were cast, for the first time, as an

official activity of the new Jakaltekek Language Academy, which provided research assistants who helped to locate subjects and to explain the tasks in the language and collect the data. These assistants later discussed the collected data with the two linguists involved: the present author and Roberto Zavala from the CIESAS-Sureste Mexican research institute, himself a specialist of neighboring Q'anjob'alan Akateko.

3.2 Types of changes observed

The richness of the data that were collected revealed many types of changes, in the midst of extreme variation of responses among speakers. The data revealed a multiplicity of possible structures, the co-existence of various types of class extension, and the invention of new classifiers.⁶

3.2.1 *Changes pertaining to non-traditional materials*

Unlike what was said of the situation in the 1970s, semantically motivated classification appeared for objects made of non-traditional but identifiable materials, such as the new glasses and plates shown in Table 2. In contrast to traditional pottery (a), rare wooden glasses/plates (mostly for decoration) appeared with an unusual CL/PLANT (b), while the omnipresent plastic ones found in the market still resisted classification, but were more systematically accompanied by the specification of their material through noun compounding as shown in (c) of Table 2.

Table 2. Variation in the expression of different kinds of glasses/plates

	CL	N1 (object)	N2 (material)
a.	<i>chèn</i>	<i>vaso/pulato*</i>	
	CL/ROCK	glass/plate	
b.	<i>te</i>	<i>vaso/pulato*</i>	
	CL/PLANT	glass/plate	
c.		<i>vaso/pulato*</i>	<i>plastiko*</i>
		glass/plate	plastic

3.2.2 *Regularized use of postnominal mention of non-traditional material*

A more widespread and systematic use of an N2 in compound structures was observed for non-traditional or even unknown materials (whether of familiar or non-familiar objects). The inventory of such N2s for materials was also much larger than before, and included a variety of Spanish loanwords (marked *) for the various types of plastic of different consistency, as shown in Table 3.

6. Grinevald (2009) has been the only presentation of this analysis of the changes.

Table 3. Construction with regularized N2 material

	[N1 object	<u>N2 material]</u>	
a.	<i>uwe</i>	<i>te'</i>	
	necklace	wood	'seed necklace'
b.	<i>bokwiè</i>	<i>qàpe</i>	
	hat	cloth	'cloth hat'
c.	<i>kaxha*</i>	<i>tz'um</i>	
	box	leather	'leather box'

For instance, as shown in Table 4, different kinds of bags, all clearly non-traditional, were named with a specification of their material using the appropriate N2.

Table 4. Different kinds of bags

	[N1 object	<u>N2 material]</u>	
a.	<i>tx'uy</i>	<i>hum</i>	
	bag	paper	'paper bag'
b.	<i>tx'uy</i>	<i>nailo*</i>	
	bag	plastic	'plastic bag'
c.	<i>tx'uy</i>	<i>qàp</i>	
	bag	cloth	'cloth bag'

It is worth noting that the language had nouns for the different materials used for these bags, such as words for paper, cloth, or plastic (the last one through a borrowing from Spanish). The point of interest here is that none of these material nouns had acquired the status of (pre-nominal) classifiers.

3.2.3 *A new case of class extension for plastic objects*

In contrast to the 1970s, when plastic objects that had become more and more common in the daily life of the Jakalteks resisted being classified, by 2001 their classification was now openly discussed by members of the Jakalteke Language Academy who proposed one of two extensions. The more traditional (older) speakers wanted to use CL/PLANT *te'*, saying that some plastic-like objects were actually made of the kind of rubber that comes from trees, which they knew from having worked on rubber plantations. The others, the majority, were favorable to using CL/ANIMAL *no'*, on perceptual grounds, saying that plastic objects, when handled, felt like they were made of the skin of a snake. In addition, it seemed that the new assignment of classifiers for plastic objects was not systematic, but rather specific to certain objects, according to unexplained criteria. Some were quite regular and stable and others quite rare. Meanwhile, Academy members promoted the standardized use of CL/PLANT *te'*, as exemplified in Table 5.

Table 5. Variation in the classification of plastic objects

a.	stable	<i>no'</i> CL/ANIMAL	<i>ula/uli'/manguera*</i> water hose
b.	rare	<i>no'</i> CL/ANIMAL	<i>linterna*</i> flashlight
c.	ALMG	<i>te'</i> CL/PLANT	<i>uk'b'al/pak'/tx'uy/pulato*</i> cup/spoon/bag/plate

3.2.4 Changes in the semantic motivation of existing classifiers

Several cases of systematic class extensions for objects of everyday use, listed in Table 6, were noted as signs of profound change in the functioning of the system.

Table 6. Systematic extension of classifiers

- a. CL/ANIMAL for all shoes, to be called *no' xanhab'* 'shoe' whether traditional leather sandals or new types of shoes, either plastic shoes, boots, or modern sneakers of non-leather material
- b. CL/ROCK (already extended to glass) as in *chèn vaso** 'glass/cup' for all drinking containers, whether made of pottery, glass, metal, plastic, or even wood (touristic containers)
- c. CL/ROCK also for all dishware, called *chèn munlab'al* 'dish' whether made of tin, glass, wood, or plastic

It is important to sense how this type of change seems to actually go beyond a simple extension of the domain of a classifier, and begins to look more like a change in the system itself, from semantically motivated categorization – even if extended from material to texture – to a grammaticalized European gender type of systematic class assignment of lexical nouns rather than of referent objects.

3.2.5 Addition of new classifiers to the inventory

In contrast to the situation of the clearly closed system of the 1970s, new pre-nominal classifiers had in fact appeared by 2001. They are from either native or borrowed source nouns (marked *) and are used with varying frequency (common or rare) to classify products of different materials, as shown in Table 7.

Table 7. Appearance of new classifiers

- a. for plastic objects

common	<i>kaucho*</i>	CL/RUBBER	spoon, flashlight
	<i>baj</i>	CL/BONE	spoon, plate, flashlight
rare	<i>naillo*</i>	CL/NYLON	bag
	<i>plastiko*</i>	CL/PLASTIC	spoon
- b. for leather and paper objects

rare	<i>tz'um</i>	CL/LEATHER	money purse, box
	<i>hum</i>	CL/PAPER	bag

Plastic objects could apparently be classified by 2001 but with much variation, using four different classifiers – three direct Spanish borrowings and one from a common native word. The classifiers for leather and paper are interesting in that they create new specific classifiers, where generics could have been used: CL/LEATHER and not generic CL/ANIMAL; CL/PAPER and not generic CL/PLANT, their specificity perhaps encoding the non-traditional nature of the material of such objects.

3.3 Conclusions on all the ongoing changes in the functioning of the system

The changes in the functioning of the system were documented through interactions with a variety of speakers and were strikingly multifaceted and extensive. The changes could be broken into various types such as: (i) a change in basic functioning, with new categorization principles; (ii) a change in the actual inventory of classifiers with the appearance of new ones; (iii) a difference in the treatment of different types of object, according to how familiar they were, so that new but now commonly used objects were categorized without regard to their material, in a lexicalized gender mode, while less commonly used objects (like different kinds of hats, traditional straw vs. wool/cloth hats) were just treated with post-nominal N2 nouns of material, with no attempt at integrating them into the classifier system; and (iv) for all the scenarios just listed, a great variation and flux in the responses of speakers (in terms of responses with/without classifiers, with/without the post-nominal material noun, and with both the same/different categorizing item).

Compared to the situation documented in the 1970s, the system appeared to be in a state of extreme flux and variation, with some usages seemingly already well established and others occurring rarely. This situation, which was made explicit by the mere process of data collection, then led to animated group discussions in the course of more or less formal debriefing sessions. As will be taken up in the next section, this state of variation and innovation was in fact a serious preoccupation for some of the speakers, particularly those involved in language planning and revitalization.

4. Discussion: Classifier systems and language contact

This study, based on first-hand observations, elicitation, and discussion, demonstrates the kind of turmoil a classifier system can undergo, by outlining the profound changes in the functioning of the Jakalteq system of noun classifiers that caught the field linguist by surprise after two decades of absence. This section will first consider under what particular sociolinguistic conditions of language contact such changes were happening, situating them in the specific context of advanced language endangerment and language revitalization efforts. Finally, to take a cyclic and long-term view of the

evolution of this particular system and to complete the picture of an evolving system, so far only considered as far back as colonial time, a glimpse at its likely origins will be offered. This proposal will combine the established fact that the system is an innovation of the Q'anjob'alan branch of the Mayan languages with a recent hypothesis to account for its origin, most likely as a structural borrowing, this time from another indigenous language of Mesoamerica. The mention of this possible origin of the system is meant to underline the importance of always keeping in mind the potentially ever-changing dynamics characteristic of classifier systems, and to recast the history of the Jakaltekt system into an earlier story of language contact.

4.1 Variation and change in an endangered language environment

It is worth remembering that the extensive variation encountered in the functioning of the Jakaltekt noun classifier system was captured through fieldwork that was meant to document this variation specifically. As already mentioned, the variables that accounted for this extensive variation included the types of speakers (traditional, older speakers versus younger semi-speakers, for instance), their level of formal education, their provenance (whether from the towns of Jacaltenango and Concepción, or from much smaller settlements, actually either more innovative or more conservative), and the level of familiarity of individuals with the object considered. This striking feature of extensive variation, going beyond the variation expected of oral tradition languages, is what Dorian (2010) specifically suggests is a trait of endangered language situations. Such variation is also a theme running through the extensive writing by Mithun on fieldwork and data collection framed in the context of language obsolescence (Mithun 1990, 2001, 2005, *inter alia*).

It is worth highlighting how this variation is only an intensification of the variation characteristic of semantically based classifier systems of oral tradition languages, with different inventories across dialects and localities, as actually shown for the noun classifier systems of the Q'anjob'alan languages by Hopkins (2012). As shown in Table 8, here reduced to the second subsystem of classifiers of the inanimate world, variation was found in the total number of classifiers and the nature of the specific and unique classifiers prior to any consideration of advanced language endangerment.

As shown in Table 8, Jakaltekt Popti' shared with all the other languages a classifier for trees and wood products, but extended this to all kinds of plants and herbs, while the other languages had a classifier specifically for plants and herbs. On the other hand, the language developed several specific classifiers for plant derived artifacts (one for cloth, one for thread, and one for rope items, made of cotton and of agave plants). Of relevance to the previous discussion of changes in the Jakaltekt system, it is also worth noting that in the 1970s Chuj already had a classifier for sheet plastic, *nayleh*, formed from a borrowing from Spanish *nailon* (English 'nylon').

Table 8. The noun classifiers (of natural classes only) of the Guatemalan Cuchumatanes (from Hopkins 2012)⁷

Popti'	Q'anjob'al (Martin)	Q'anjob'al (Montejo)	Akateko	Chuj	Gloss
<i>no'</i>	<i>no'</i>	<i>no'</i>	<i>no'</i>	<i>nok'</i>	ANIMAL
<i>te'</i>	<i>te'</i>	<i>te'</i>	<i>te'</i>	<i>te'</i>	WOOD, TREE
<i>'ixim</i>	<i>xim</i>	<i>(i)xim</i>	<i>'ixim</i>	<i>'ixim</i>	MAIZE, GRAIN
<i>tx'anh</i>	<i>tx'an</i>	<i>tx'an</i>	<i>ch'an</i>	<i>ch'anh</i>	CORD, VINE
<i>tx'otx'</i>	<i>tx'otx'</i>	<i>tx'otx'</i>	<i>tx'otx'</i>	<i>lum</i>	EARTH
<i>ch'en</i>	<i>ch'en</i>	<i>ch'en</i>	<i>ch'en</i>	<i>ken</i>	STONE
<i>ha'</i>	<i>ha'</i>	<i>ha'</i>	<i>ha'</i>	<i>ha'</i>	WATER
<i>q'a'</i>	<i>q'a'</i>	<i>q'a'</i>	<i>q'a'</i>	–	FIRE
<i>'atz'am</i>	–	<i>tz'am</i>	<i>'atz'am</i>	<i>'atz'am</i>	SALT
–	<i>'an</i>	<i>'an</i>	<i>'an</i>	<i>'anh</i>	PLANT, HERB
<i>q'ap</i>	–	–	–	<i>kapak</i>	CLOTH
<i>metx'</i>	–	–	–	–	DOG
<i>tx'al</i>	–	–	–	–	THREAD
–	–	<i>q'inal</i>	–	<i>k'inal</i>	RAIN
–	–	–	–	<i>yap'il</i>	ILLNESS
–	–	–	–	<i>nayleh</i>	SHEET PLASTIC

The key goal of the planned fieldwork was to capture the variation, specifically investigating how the speakers were verbally treating the new objects of their environment, and looking for how they incorporated them into the language, whether in the classification system or not. In fact, the discussions that followed the data collection sessions revealed in interesting ways a strong divergence in attitudes and ideologies among the participants, between traditionalists and modernists, including activists of both leanings.

4.2 An endangered Mayan language in the midst of revitalization efforts

Of all the countries of Latin America that still have important indigenous populations today, Guatemala stands out because of its impressive language planning efforts of the last decades. Interestingly, it is a country where foreign linguists have taken an early

7. The information can be found in Craig (1986) for Popti'; Martin (1977) and Montejó & Pedro (1996) for Q'anjob'al; Zavala (1989) for Akateko; Hopkins (1967) for Chuj.

part in actively promoting and accompanying some of the processes, in particular the training of native Mayan linguists (England 1992a & b, Grinevald 2002). Among the Mayan languages of Guatemala, the Jakaltek Popti' language stands out as one of the smallest languages and, today, as one of the most endangered. It was also the last one to create its own branch of the Academy of Mayan Languages of Guatemala.

As already mentioned, the fieldwork sessions were specifically organized and run with the help of members of this local Academy; the final discussions about the collected data took place in the Academy meeting place itself. The members of the Academy participating in the discussions were obviously concerned about the need they felt for standardization. This meant simplification and normalization, as in assigning a classifier to every object noun, and making up new rules for these assignments. One of the concerns was that the absence of classifiers meant a corresponding absence of anaphoric pronouns. Hence, to maintain the functionality of the grammatical anaphoric system, the introduction of more and more new items used in daily life needed to be counteracted with some systematic classification. It was clear that this concern of the members of the academy was coming from pressure from the dominant Spanish language, taken as the model of a "better language", with its obligatory article and pronominal forms organizing the vocabulary through gender-marking.

These intense discussions on the new usages of classifiers are not echoed, however, in the various publications on the Jakaltek Popti' language produced by the local academy (Comunidad Lingüística Jakalteka) through the Academia de Lenguas Mayas (ALMG 2001a, b, c) nor by other language activists (such as Mendez Cruz 1997, or even in his subsequent writings), even when they specifically address issues of modernization and standardization of the language in support of educational programs in Jacaltenango. Neither is this topic of a renewed classifier system discussed in the 2007 first edition of "Gramática Normativa Popti'" (Delgado Rojas et al. 2007). What is necessary now is of course to return to the field in order to observe whether and how the dust has settled, to again compare how speakers are coping today with the new items of modern times and how the issue is handled in official discourse and writings. Finally, one could look into the extent to which this official discourse is echoed in the teaching and learning of the language through bilingual school programs.

4.2 Epilogue on cycles of classifier systems and language contact

Classifier systems are known to be lexico-grammatical systems of much plasticity, which can provide snapshots of certain moments in the cultural development of a people, as long as they maintain enough semantic motivation. Classifier systems are born at certain times and places, some emerging language-internally from other source constructions available in the language, others borrowed as a result of language contact through a process of structural rather than lexical borrowing. Hence the areal

phenomena of classification systems documented for various parts of the world.⁸ As will be suggested below, the emergence of the Jakaltek Popti' system may well have been through a combination of both innovation and borrowing.

The conclusion reached in Craig (1990) about the origins of the Jakaltek noun classifier system and of all the similar noun classifier systems of the Q'anjob'alan languages, was that it was a case of an apparent innovation of this branch of the family. This conclusion relied on two sources of information. One was the collection of descriptions produced in the 1980s, showing the similar systems of the other Q'anjob'alan languages of the mountainous Cuchumatanes region of Guatemala, such as Hopkins (1967) for Chuj, Martin (1977) for Q'anjob'al, and Zavala (1989) for Akatek, although all with different inventories. The other was the advanced comparative and historical reconstruction of the Mayan family done by Kaufman (1974) and his schema of the development of the Mayan family of languages, dating the split of the Q'anjob'alan branch around 500 AD,⁹ as shown in Figure 2.

This analysis shown in Figure 2 of the origin of the noun classifiers as an innovation at about the time of the split of the Q'anjob'alan branch had however left pending the mystery of why this sudden innovation then and there. A recent proposal (Hopkins 2012) has suggested an interesting scenario of borrowing under contact, offering the hypothesis that it was due to contact with Otomanguean languages of Mexico, a very large and once dominant family that spread all the way down the Pacific coast from Mexico to Nicaragua and Costa Rica in lower Central America. As it happens, some sort of noun classification system has indeed been described as a morphosyntactic characteristic of a number of Otomanguean languages, as detailed in the work of de León (1988) for Mixtec for instance. When comparing the Otomanguean and Q'anjob'alan systems, one can recognize how they share similar kinds of categorization (including not classifying abstract nouns), similar morphosyntactic status with nominal prefixation and anaphoric pronominal enclitics, and parallel grammaticalization of identifiable free nouns used as lexical sources. At this point, however, it would still be necessary to strengthen the demonstration of how contact indeed took place between languages with such systems and the Q'anjob'alan languages.

8. See for instance the spreading of numeral classifiers in the South East Asian region discussed by Bisang (1999) or that of a combination of classification systems typical of the Amazon region discussed by Seifart and Payne (2007) and Aikhenvald (2012).

9. Although the dating is originally based on a glottochronological approach, enough comparative work on the languages of the family is available to not find reason to doubt this time estimate. Issues regarding which languages belong or not to the Q'anjob'alan branch might change the date by a couple centuries or so, although this would not affect the main line of reasoning here.

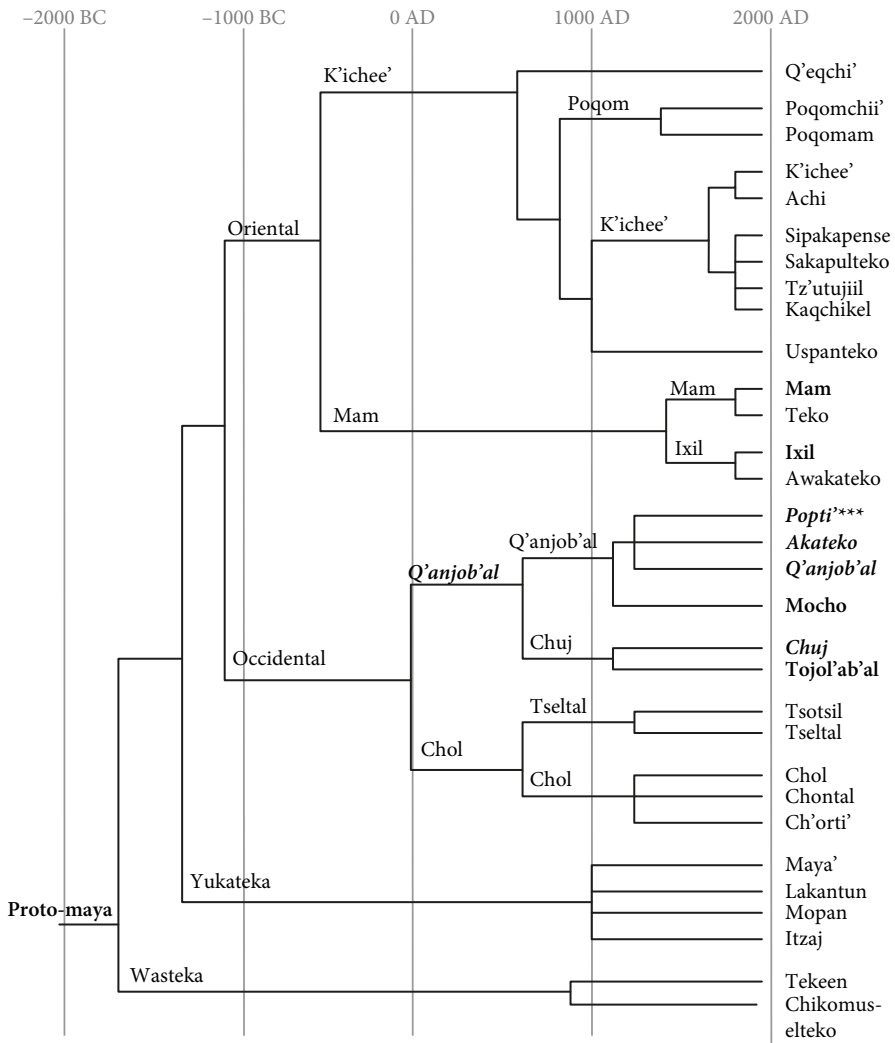

Figure 2. The Mayan family
(from Kaufman 1974 in Hopkins 2012)¹⁰

In any case, the fact is that noun classifier systems are a typologically rare subsystem of classifiers and are specifically found in that region of the world, in distinct families of languages. Hopkins's hypothesis suggests a scenario of structural borrowing, i.e., the borrowing of the idea of a nominal classification system facilitated by the heavy

10. Bold font is used for languages known to have noun classifiers, and those in italics are the source languages from which the system spread to the neighboring ones of other branches.

semantic motivation of the system. In support of this analysis of borrowing under contact is the presence of a partial noun classifier system (just the social interaction part of it) in the neighboring Mam of the Mamean distinct branch, originally considered to be a secondary borrowing from Q'anjob'alan (Craig 1990, England 1992a), though it could have been an early borrowing from Otomanguean languages.

This proposal that the origin of the noun classifier systems of Q'anjob'alan languages was a case of structural borrowing from other indigenous languages could be strengthened further by noting that it seems to have fallen on fertile grounds in Mayan languages on two accounts. First, as mentioned in Craig (1990), the Mayan tradition of using titles for human protagonists in nominal constructions may have facilitated this innovation. Then, going further back in time, and as noted by Hopkins (2012), new studies such as Mora-Marín (2002) have also shown the existence of semantic markers akin to classifiers in some Mayan hieroglyphs.¹¹ Much remains to be done to strengthen and further explore this hypothesis, but the idea that internal Mayan evolution and language contact with other indigenous languages were converging at the origin of the innovation of a system of classification in a specific branch of the family seemed worth mentioning as a way of keeping in mind the plasticity of classifier systems, and the need to always pay attention to their dynamics at the moment of describing them.

One of the points of this piece of writing was to support Mithun's repeated recommendation, when carrying out fieldwork, to gather ample data on a language as it presents itself in all its varying forms, independent of current linguistic discussions and debates, particularly when this fieldwork is on endangered languages. It is in support of this stance that this writing outlined how data about the noun classifier system of Jakaltek gathered in the 1970s only later fed into discussions and debates, leading to a career-long exploration of the nature of classifier systems (Grinevald 2000 to Grinevald 2015), in a constant feeding relationship of description, typology, and theory, with a tinge of diachrony. It finally turned to the issue of how the last documented extensive changes in the functioning of the system were due in part to language contact. This system is an example of the kind of topic that enters into contemporary debates concerning the fate of highly endangered languages, particularly when caught in language revitalization efforts oriented to modernization and standardization of a language. The standardization pressure induced by contact with Spanish could potentially lead to the Jakaltek classifier system increasingly imitating a European gender system, considered "better" because it is more regular, though less semantically motivated.

11. Interestingly, those semantic markers were unpronounced, much like the so-called determiners of Egyptian hieroglyphs, now considered to be classifiers (Goldwasser and Grinevald 2012).

References

- Aikhenvald, Alexandra Y. 2012. *The Languages of the Amazon*. Oxford: Oxford University Press. doi:10.1093/acprof:oso/9780199593569.001.0001
- Academia de Lenguas Mayas de Guatemala (Comunidad Lingüística Jakalteka). 2001a. *Stzotib'ál Popti'. Vocabulario Jakalteko (Popti')*. Ciudad de Guatemala.
- Academia de Lenguas Mayas de Guatemala (Comunidad Lingüística Jakalteka). 2001b. *Ak'b'òj payat tzoti' yul ab'xub'ál popti'*. *Actualización lexical idioma maya jakalteko (Popti')*. Ciudad de Guatemala.
- Academia de Lenguas Mayas de Guatemala (Méndez Cruz, A.F.) 2001c. *Stxolb'anil Ab'xub'ál Popti'. Gramática descriptiva jakalteka Popti'*. Ciudad de Guatemala.
- Berlin, Brent. 1968. *Tzeltal Numeral Classifiers: A Study in Ethnographic Semantics*. The Hague: Mouton.
- Bisang, Walter. 1999. Classifiers in East and Southeast Asian languages: Counting and beyond. In *Numeral Types and Changes Worldwide*, Jadranka Gvozdanovic (ed), 113–185. Berlin: Mouton de Gruyter.
- Breitborde, Lawrence B. 1973. Selection and Setting in Jacaltec Noun Classifier Usage. Paper presented at the summer meetings of the Linguistic Society of America. Ann Arbor MI.
- Craig, Colette. 1977. *Jacaltec Syntax: A Study of Complex Sentences*. Austin TX: University of Texas Press.
- Craig, Colette. 1979. Jacaltec: Fieldwork in Guatemala. In *Languages and Their Speakers*, Timothy Shopen (ed.), 3–57. Cambridge MA: Winthrop.
- Craig, Colette. 1986. Jacaltec noun classifiers: A study in language and culture. In *Noun Classes and Categorization* [Typological Studies in Language 7], Colette G. Craig (ed.), 263–295, Amsterdam: John Benjamins. doi:10.1075/tsl.7.17cra
- Craig, Colette. 1987. Jacaltec noun classifiers: A study in grammaticalization, *Lingua* 70(4): 241–284. doi:10.1016/0024-3841(86)90046-X
- Craig, Colette. 1990. Los clasificadores de nombre en Jacalteco: una innovación kanjobalana. In *Lecturas sobre la lingüística maya*, Nora C. England & Stephen R. Elliot (eds), 221–252. Antigua, Guatemala: CIRMA.
- Craig, Colette. 1992. Classifiers in a functional perspective. In *Layered Structure and Reference in a Functional Perspective: Papers from the Functional Grammar Conference, Copenhagen, 1990*, Michael Fortescue, Peter Harder & Lars Kristoffersen (eds), 277–303. Amsterdam: John Benjamins. doi:10.1075/pbns.23.12cra
- Day, Christopher. 1973. The semantics of social categories in a transformational grammar of Jacaltec. In *Meaning in Mayan Languages*, Munro S. Edmonson (ed.), 85–105. The Hague: Mouton.
- de León, Lourdes. 1988. Noun and Numeral Classifiers in Mixtec and Tzotzil: A Referential View. Ph.D. dissertation, University of Sussex.
- Delgado Rojas, Edna Patricia, Silvestre Sanchez, José Aurelio, Silvestre Diaz, María Elizabeth & Ross Montejo, Antonio Benicio. 2007. *Stz'ib'nhebanil ab'xub'ál popti'*. *Gramática normativa Popti'*. Guatemala City: Academia de Lenguas Mayas de Guatemala.
- Dorian, Nancy C. 2010. *Investigating Variation: The Effects of Social Organization and Social Setting* [Oxford Studies in Sociolinguistics]. Oxford: Oxford University Press. doi:10.1093/acprof:oso/9780195385939.001.0001
- England, Nora C. 1992a. *Introducción a la lingüística: Idiomas mayas*. Guatemala: PLFM, Editorial Cholsamaj.

- England, Nora C. 1992b. Endangered languages: Doing Mayan linguistics in Guatemala. *Language* 68(1): 29–35. doi:10.1353/lan.1992.0073
- Goldwasser, Orly & Grinevald, Colette. 2012. What are determinatives good for? In *Lexical Semantics in Ancient Egyptian* [Lingua Aegyptia Studia Monographica 9], Eitan Grossman, Stéphane Polis & Jean Winand (eds), 17–53. Hamburg: Widmaier Verlag.
- Grinevald, Colette. 2000. A morpho-syntactic typology of classifiers. In *Systems of Nominal Classification*, Gunter Senft (ed.), 50–92. Cambridge: Cambridge University Press.
- Grinevald, Colette. 2002. Linguistique et langues mayas du Guatemala. [Faits de Langues 20]. Meso-Amérique, Caraïbes, Amazonie Volume 1: 17–27. Paris: Ophrys.
- Grinevald, Colette. 2006. Encounters at the brink: Linguistic fieldwork among speakers of endangered languages. In *The Vanishing Languages of the Pacific Rim*, Chapter 3, Osahito Miyaoka, Osamu Sakiyama, & Michael E. Krauss (eds), 35–76. Oxford: Oxford University Press.
- Grinevald, Colette. 2009. The (Jakalteq) Popti' noun classifier system: From its origins to recent developments. *The Diachrony of Classification Systems COST Workshop (Action A31)*, Paper given in Wassenaar, 12–14 March.
- Grinevald, Colette. 2010a. Quarante ans de perspective sur deux langues en danger: Le jakalteq popti' du Guatemala et le rama du Nicaragua. In *Linguistique de terrain sur langues en danger: Locuteurs et linguistes* [Faits de Langues 35–36], Colette Grinevald & Michel Bert (eds), 39–78. Paris: Ophrys.
- Grinevald, Colette. 2010b. Linguistique de terrain sur LED: Locuteurs et méthodes. In *Linguistique de terrain sur langues en danger: Locuteurs et linguistes* [Faits de Langues 35–36], Colette Grinevald & Michel Bert (eds), 133–177. Paris: Ophrys.
- Grinevald, Colette. 2015. Classifiers, Linguistics of. In *International Encyclopedia of the Social and Behavioral Sciences*, 2nd edn., Vol. 3, James Wright (ed.), 811–818. Oxford: Elsevier. doi:10.1016/B978-0-08-097086-8.53003-7
- Hopkins, Nicholas Arthur. 1967. The Chuj Language. Ph.D. dissertation, University of Chicago.
- Hopkins, Nicholas Arthur. 2012. The noun classifiers of the Cuchumatanes: A case of diffusion from Otomanguean. *International Journal of American Linguistics* 78(3): 411–427. doi:10.1086/665919
- Kaufman, Terrence S. 1974. *Idiomas de Mesoamérica* [Seminario de Integración Social Guatemala 33]. Guatemala City: Editorial José de Pineda Ibarra y Ministerio de Educación.
- La Farge, Oliver & Byers, Douglas. 1931. *The Year Bearer's People* [Middle American Research Institute Series 3]. New Orleans LA: Tulane University Press.
- Lucy, John A. 1996. *Grammatical Categories and Cognition: A Case Study of the Linguistic Relativity Hypothesis*. Cambridge: Cambridge University Press.
- Martin, Laura Ellen. 1977. Positional Roots in Kanjobal. Ph.D. dissertation, University of Florida.
- Méndez Cruz, Atonio Feliciano. 1997. *Diccionario Popti' (Jakalteko)-CASTELLANO Morfosemántico. Hej stzot'i'al jab'xub'al*. Ciudad de Guatemala: Nawal Wuj, NORAD.
- Mithun, Marianne. 1990. Language obsolescence and linguistic description. *International Journal of American Linguistics* 56: 1–26. doi:10.1086/466136
- Mithun, Marianne. 2001. Who shapes the record: The speaker and the linguist. In *Linguistic Fieldwork*, Paul Newman & Martha Ratcliff (eds), 34–54. Cambridge: Cambridge University Press. doi:10.1017/CBO9780511810206.003
- Mithun, Marianne. 2005. Grammars and the community. *Studies in Language* 30(2): 281–306. doi:10.1075/sl.30.2.06mit

- Montejo, Ruperto & De Nicholas, Pedro. 1996. *Gramática del idioma q'anjob'al*. Antigua, Guatemala: Proyecto Lingüístico Francisco Marroquín.
- Mora-Marín, David F. 2002. Full phonetic complementation, semantic classifiers, and semantic determinatives in ancient Maya hieroglyphic writing. *Ancient Mesoamerica* 19(2): 195–213. doi:10.1017/S0956536108000345
- Rehg, Kenneth L. 1981. *Ponapean Reference Grammar* [PALI Language Texts: Micronesia]. Honolulu HI: University Press of Hawaii.
- Seifart, Frank & Payne, Doris. 2007. Nominal classification in the North West Amazon: Issues in areal diffusion and typological characterization. *International Journal of American Linguistics* 73(4): 381–387. doi:10.1086/523770
- Zavala Maldonado, Roberto. 1989. Los clasificadores nominales del kanjobal de San Miguel Acatán: Esbozo gramatical y tipología de sistemas clasificatorios. Tesis de licenciatura. Escuela Nacional de Antropología e Historia. México, D.F.
- Zavala Maldonado, Roberto. 2000. Multiple classifier systems in Akatek (Mayan). In *Systems of Nominal Classification*, Gunter Senft (ed.), 114–146. Cambridge: Cambridge University Press.

